

EN



Operation manual

Air heaters

PLANAR – 9D – 12

PLANAR – 9D – 24

Table of Contents

1	Introduction	3
2	Basic parameters & specifications	3
3	Safety Measures.....	4
4	Description of Heater Structure and Operation.....	5
5	Heater control unit.....	6
6	Control panel	6
7	Scope of Supply.....	9
8	Installation requirements	10
9	Post-installation testing	16
10	Recommendations	17
11	Possible malfunction during operations and Remedial Procedure for Heater Ignition Problems	18
12	Transportation & storage.....	19
13	Warranty	19

Production
ADVERS LLC
 Novo-Sadovaja str. 106,
 443068, Samara, Russia
 +7(846)263-07-97
www.autoterm.ru

Sales Department
AUTOTERM LLC
 Trikatas 4, Riga, Latvia
 LV-1026
 +371 20110229
sales@autoterm-europe.com
www.autoterm-europe.com

Technical Support
AUTOTERM LLC
 Trikatas 4, Riga, Latvia
 LV-1026
 +371 25529999
service@autoterm-europe.com

1 Introduction

This operation manual is intended to familiarize the User with salient features, operation, assembly and operating procedures for PLANAR-9D-12, PLANAR-9D-24, (hereinafter called «the heater») intended for regulated heating of various compartments of a motorized vehicles at atmospheric temperatures as low as -45°C (-113°F).

Minor changes performed on the heater structure by the Manufacturer may not be documented in this operation manual.

When placing an order or referring to the heater in documents pertaining to other types of equipment, the heater codes will read as follows:

«Отопитель воздушный / Air Heater PLANAR-9D-12 TU4591-008-40991176-2005»;
 «Отопитель воздушный / Air Heater PLANAR-9D-24 TU4591-008-40991176-2005»;

2 Basic parameters & specifications

The basic heater specifications are quoted in Table 1.

The basic parameters are quoted to a margin of $\pm 10\%$ tolerance at a temperature of 20°C (68°F) at a nominal voltage.

Table 1

Parameter Code	Version			
	PLANAR-9D-12		PLANAR-9D-24	
Nominal Supply Voltage, V	12		24	
Fuel Type	diesel oil in compliance with GOST 305, atmospheric temperature-dependent			
Heating Efficiency:	max, kW	min, kW	max, kW	min, kW
	8	3,2	8	3,2
Heated Air Volume:	max, m ³ /h	min, m ³ /h	max, m ³ /h	min, m ³ /h
	290	70	290	70
Fuel Consumption at:	max power, l/h	min power, l/h	max power, l/h	min power, l/h
	1	0,42	1	0,42
Power consumption, W	max, W	min, W	max, W	min, W
	215	12	180	12
Start/Stop Mode	Manual			
Maximum Weight, kg	18			

3 Safety Measures

- 3.1. The installation of the heater and its fittings shall be performed by authorized organizations only.
- 3.2. The heater may only be used for the purposes specified herein.
- 3.3. The fuel supply line shall not be installed inside the passenger compartment or cabin of a motor vehicle.
- 3.4. The vehicle electric harness shall not be installed near the fuel supply line.
- 3.5. A vehicle that uses the heater shall be equipped with a fire extinguisher.
- 3.6. It is prohibited to use the pre-heater in areas, where highly inflammable vapors or ample quantity of dust may be generated or accumulated.
- 3.7. To prevent the possibility of exhaust gas poisoning, the heater shall not be used when the vehicle is in the closed, not aired rooms (garage, workshop, etc).
- 3.8. When refueling the vehicle, the heater shall be switched off.
- 3.9. When performing welding operations on the vehicle or repairs on the heater, disconnect the heater from the vehicle battery.
- 3.10. When assembling or dismantling the heater, observe the safety measures specified by electric work regulations for the fuel supply system and the vehicle's wiring system.
- 3.11. The heater shall not be connected to the vehicle electric circuit while the engine is running or the battery is switched off.
- 3.12. The heater's electric power supply must not be disconnected before the end of the purge cycle.**
- 3.13. The heater is powered from the accumulator battery regardless of the availability of the vehicle frame connection.
- 3.14. The heater's connectors must not be connected or disconnected while the heater's electric power supply is turned on.
- 3.15. It is forbidden to step on a heater and to put on it subjects.
- 3.16. It is forbidden to cover a heater with articles of clothing, pieces of fabric, etc. and as to place them before its entrance or an exit of heated air.
- 3.17. Wait 5 to 10 seconds before switching the heater back on.
- 3.18. In the event of two subsequent ignition failures, contact the maintenance department to report a malfunction.
- 3.19. In the event of a failure in heater operation, contact a designated repair organization authorized by the manufacturer.
- 3.20. Manufacturer warranty shall not apply if the above requirements are not adequately met.

4 Description of Heater Structure and Operation

The heater operates independently from the vehicle engine.

The fuel and electric power supply is provided by the vehicle. See figure 4.1 for the heater wiring diagram.

The heater is a self-contained heating device comprising the following:

- heating device (see figure 4.2 for basic components thereof);
- fuel supply pump providing fuel for the combustion chamber;
- ignition and indicator device (control panel);
- wiring harness connecting heater fittings to the vehicle battery.
- fuel tank

The heater's operating principle is based on heating air driven through the heater's heat exchange system.

The heat sources are fuel combustion gases from the combustion chamber. The resulting heat warms the walls of the heat exchanger, which is air-blown from the outside. Air passes through the ribbing of the heat exchanger and enters the passenger compartment or other compartments of the vehicle.

Upon ignition, control unit of the heater checks the heater to ascertain whether fittings such as the flame indicator, the overheat sensor, air pump motor, plugs, fuel supply pump and the electric circuits thereof are working properly.

If no problem is detected, the ignition process starts.

In accordance with the preset sequence, the combustion chamber is fore-purged and the glow plug warms up to the required temperature. Air and fuel starts to enter the combustion chamber under the same procedure, whereupon the ignition process is initiated. Once stable combustion is achieved, the heating plug switches off. Flame control is provided by the flame indicator. All processes involved in heater operation are monitored by the control unit.

The control unit controls heat exchanger temperature and halts the combustion process as soon as the temperature exceeds the specified limit and the temperature of the heated air. The heater may be switched off at any time.

Pressing the heater deactivation command stops the fuel entering and the combustion chamber is purged with air.

During automated operation control of the heater in emergency situations, bear in mind the following:

- 1) in the event of ignition failure, the process will be repeated. The heater will switch off following two consecutive ignition failures;
- 2) if in a operating time of a heater, a burning stops, then the attempt of starting will be repeated. In operating time of a heater a flameout is possible till 3 times;
- 3) if the heat exchanger is overheated (maybe as a result of closure of the heater inlet/outlet vents), the heater will switch off automatically,
- 4) if the heated air is overheated maybe as a result of closure of the heater inlet/outlet vents), the heater will switch off automatically.
- 5) if voltage drops below 20 V (10 V) or exceeds 30 V (16 V) the heater will switch off;
- 6) at emergency switching off of a heater on the control panel (CP) the light-emitting diode blinks. The quantity of blinking corresponds to an error code. Watch an error code in the manual of control panel.

5 Heater control unit

The control unit and the control panel control the heater.

The control unit performs the following functions:

- a) initial diagnostics (serviceability check) of heater fittings during ignition,
- b) diagnostic of heater elements throughout operation,
- c) heater activation/deactivation by command from control panel;
- d) combustion process control;
- e) automated switching of ventilation after the combustion process stopped;
- f) automated deactivation of the heater occurs:
 - in the event of failure of one of the controlled elements,
 - when any parameter exceeds the specified limit (heat exchanger temperature, air temperature, supply voltage)
 - combustion chamber flame failure (more than 3 times)

6 Control panel

On the front panel of the control panel are located:

- 1 – Button on/off ventilation mode;
- 2 – Button on/off heater;
- 3 – Light-emitting diode to display of working of heater;
- 4 – Light-emitting diode to display of the mode of ventilation;
- 5 – Potentiometer handle.

The light-emitting diode pos. 3 shows a mode of working of a heater:

- shines yellow – the heating mode;
- blinks often yellow – during a purge;
- blinks seldom red – at malfunction of heater;
- doesn't shine – at an not working heater.

The light-emitting diode pos.4 shows a condition of the mode of ventilation:

- shines green – if the cabin temperature sensor isn't connected and the heater works in the ventilation mode;
- blinks green – switching off of the mode of ventilation;
- shines yellow – if the cabin sensor is connected and the heater works at the heating mode with ventilation function;
- doesn't shine at an idle heater and at the switched-off ventilation mode.

Work with the control panel is described in manual on the control panel.

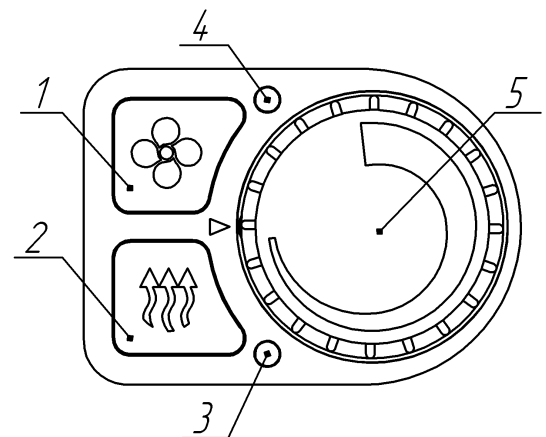

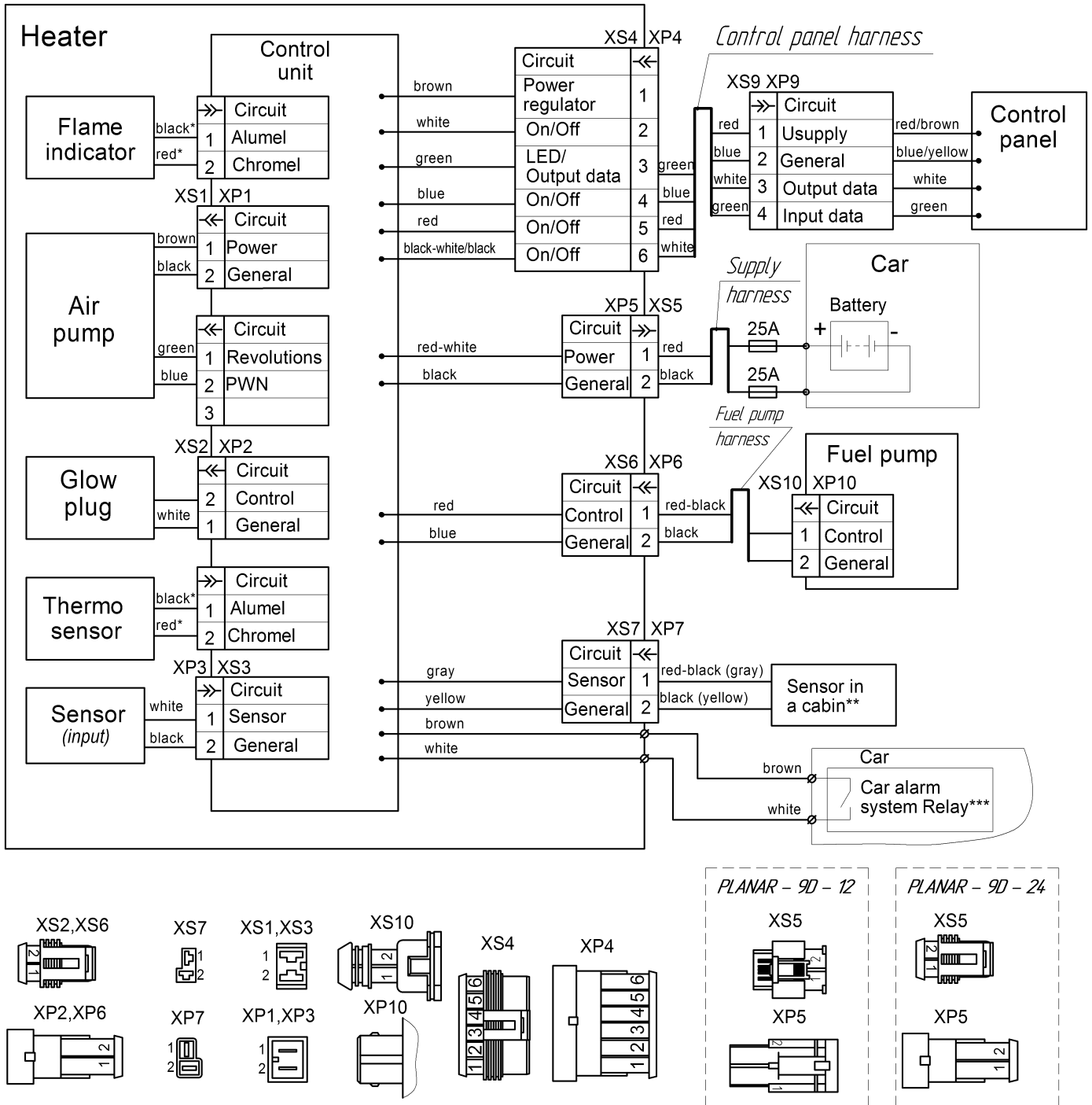

1. View of connector (XS1, XS3, XS7, XP1, XP3, XP7) is shown from contact side (not from wires side).
2. *color of a tag on wires
3. **to buy in addition

Figure. 4.1- Wiring diagram

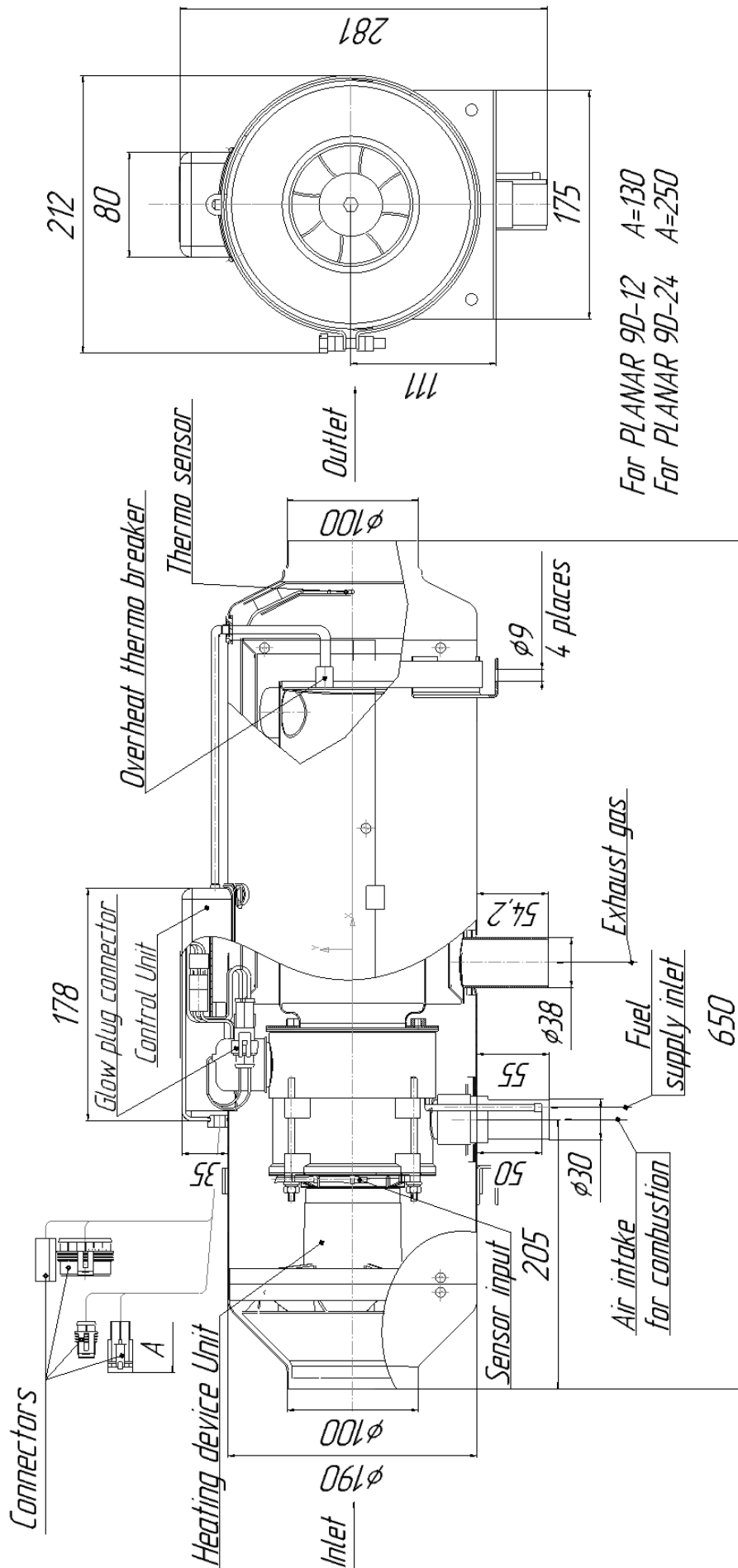

Figure 4.2 – Basic heater components

7 Scope of Supply

See figure 7.1 for scope of supply and connection diagram of basic heater components PLANAR-9D-12, PLANAR-9D-24.

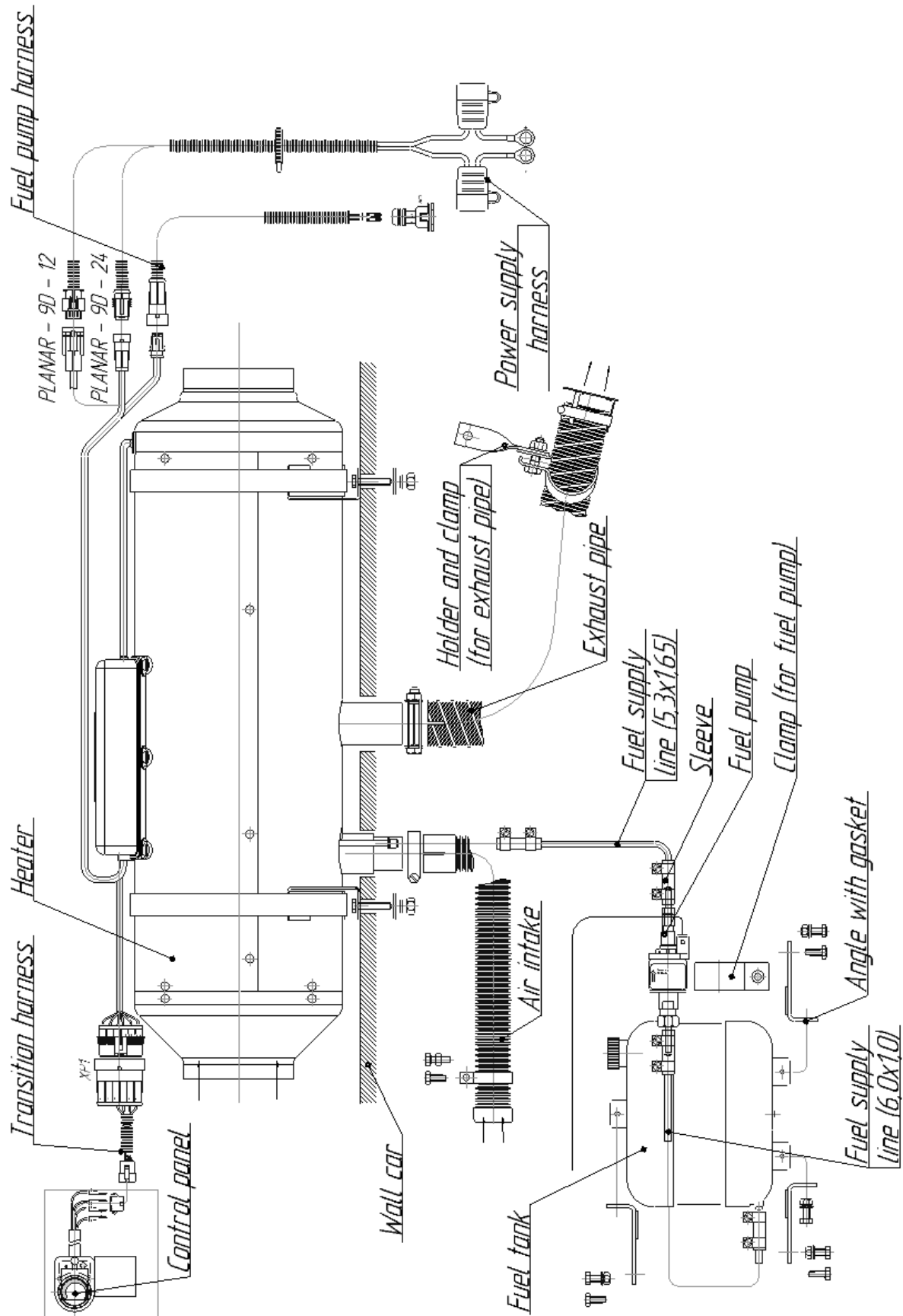

Figure 7.1 – Connection diagram of basic heater components

8 Installation requirements

8.1. Heater installation

Install the heater according to figure 8.1. Peace of installation for the heater should be flat. Position the heater's inlet vent in such a way to prevent absorption of vehicle/heater exhaust gas in normal operating conditions. The distance between the walls/partitions and the edge of the inlet vent shall be at least 100 mm (see figure 8.1). The distance between the walls/partitions and the edge of the outlet vent shall be at least 250 mm. When assembling or operating the heater, ensure that no foreign objects enter the inlet/outlet vents. Prior to assembly, ensure availability dismantlement requirements, as this will permit easier maintenance in future.

See figure 8.1b how to position mounting holes to install the heater into the motor vehicle casing.

ATTENTION!!! To ensure reliable performance, follow the above recommendations carefully. Install the heater horizontally as shown on the figure 8.1.

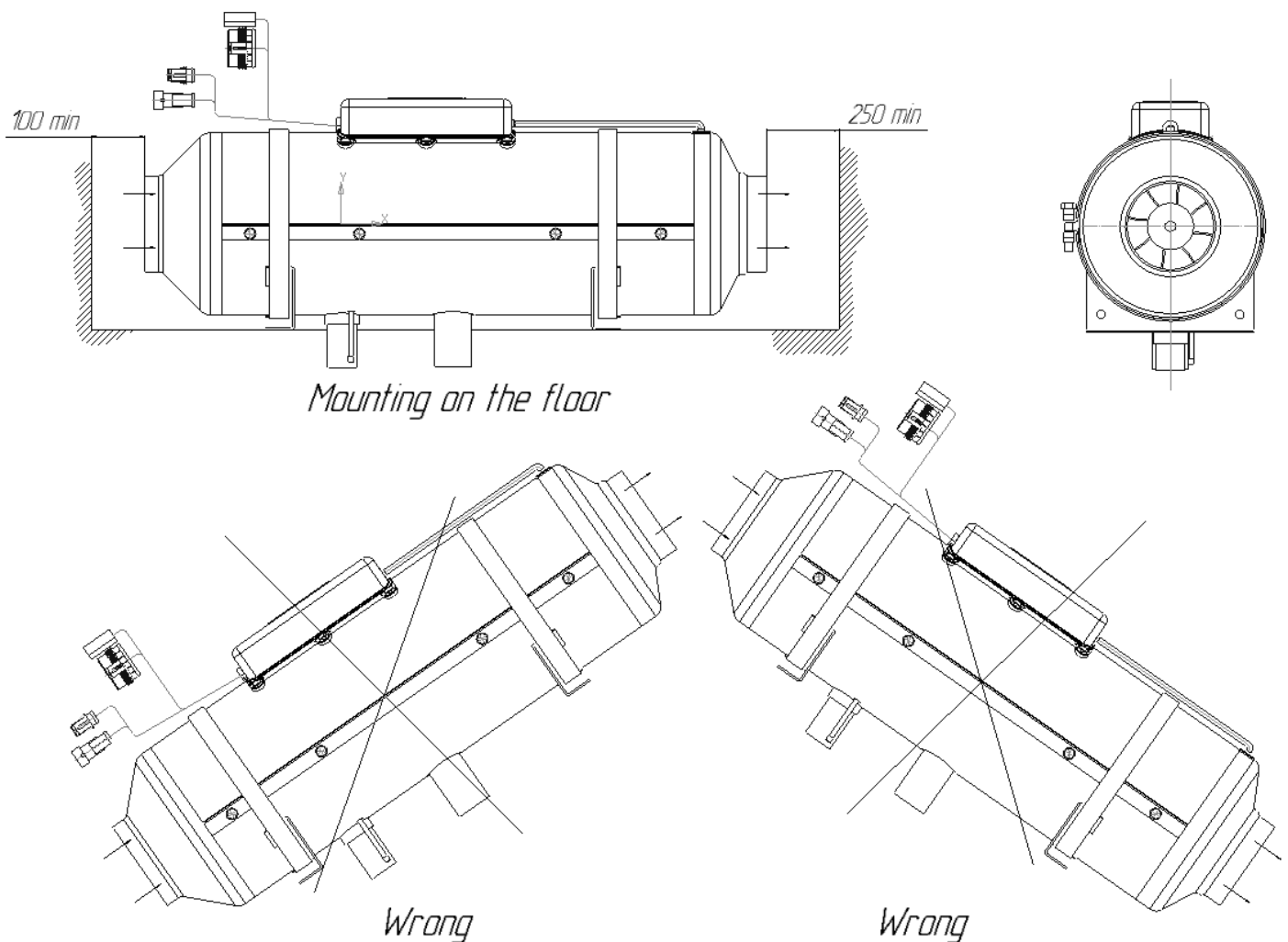

Figure 8.1 – Variants of installation of a heater.

At installation of the heater check that its case had no contact both with a floor and with other parts of a cabin or a manned compartment. Non-performance of this requirement can lead to deformation of the heater case, jamming of the air fan and a possible overheat.

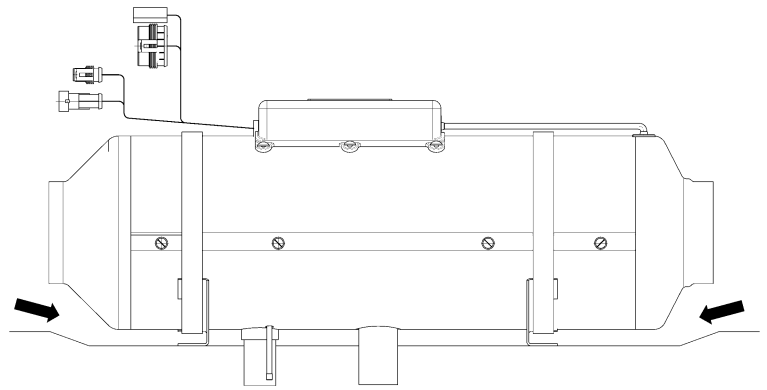

Fig. 8.1a - reserve free space

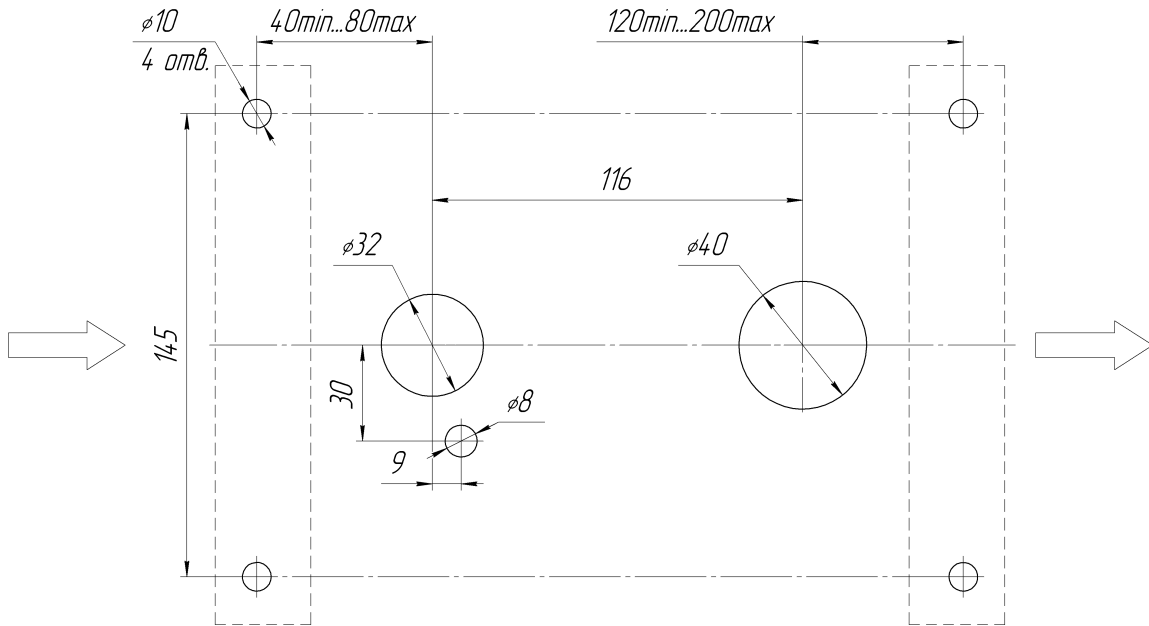

Figure 8.1b- Mounting holes used for heater installation

8.2. Air inlet installation

Air necessary for burning, should not be soaked up from salon or a cabin and a car luggage space. Position the pipe's air inlet vent to prevent snow entering or choking the pipe and to allow incoming water to run off. The entrance aperture of an air inlet is forbidden to have against a running air stream at car movement.

8.3. Exhaust pipe installation

When installing the exhaust pipe, be mindful of its high operating temperature. Exhaust pipe is fixed with clamps.

Direct exhaust gas outside. Position the gas outlet vent and the air inlet vent in such a way as to prevent exhaust gas from entering the combustion chamber.

Ensure that exhaust gas does not enter the passenger compartment of the vehicle and that it does not get sucked in through the vehicle fan. Do not allow exhaust gas to affect the performance of vehicle components. Position the exhaust pipe outlet vent so as to prevent snow entering or choking the pipe and to allow incoming water to run off. The exhaust outlet of an exhaust pipe is forbidden to have against a running air stream at car movement.

At the vent of the exhaust pipe the screen is installed, this is necessary for stable operation of the heater while working low idle.

Attention! At installation of a heater into the volume of vans (isothermal boxes, minibuses, etc.) the arrangement of an exhaust pipe and an air inlet on opposite boards is inadmissible. Installation of exhaust and air intake pipes through one board is correct. The distance between them has to exclude repeated absorption of exhaust gases through an air inlet (not less 200mm).

Non-performance of the listed recommendations under adverse conditions (a strong wind, of pressure differences) not only interferes with an exit of exhaust gases, but also creates additional discharge in an air intake zone. As a result normal work of a burner is at a loss, there is its contamination soot and heater service life is reduced.

In rare instances non-performance of this recommendation can lead to hit of a flame in the blower of air pump.

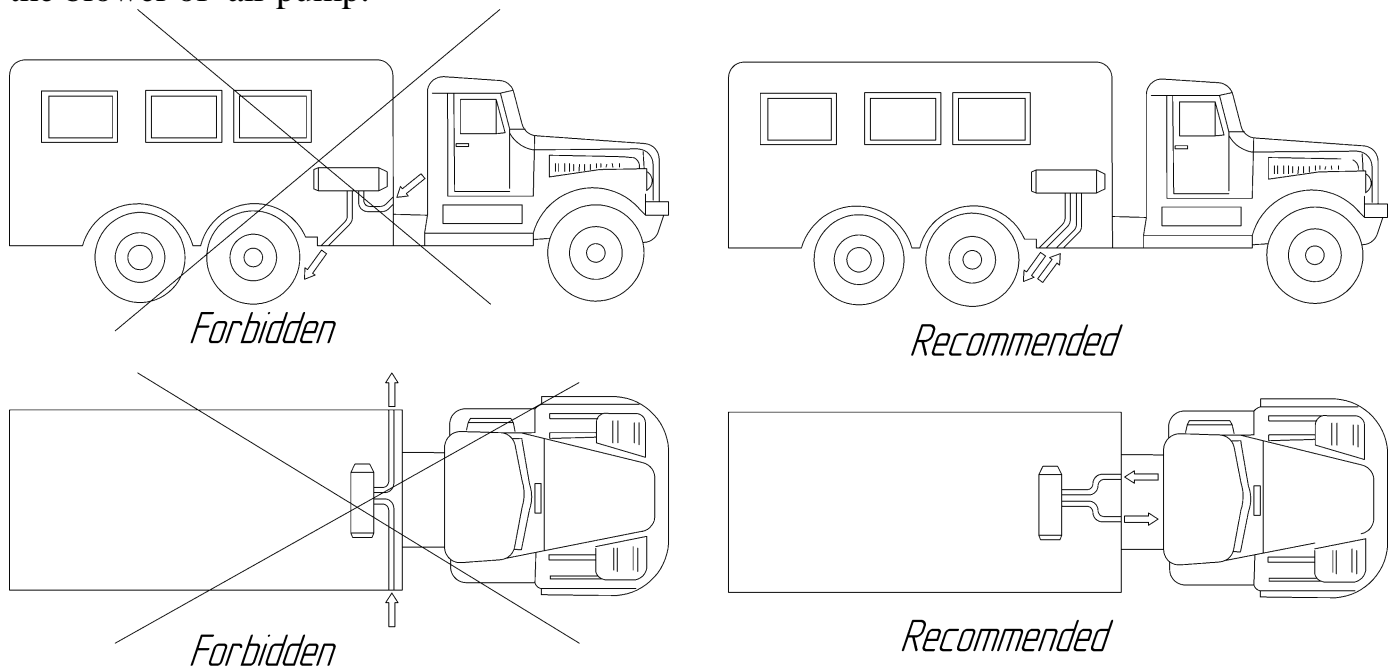

Fig.8.3a – recommended position.

8.4. Installation of heater fuel supply system

To prevent emergency situations, follow these instructions carefully

8.4.1. Installation of heater fuel pump and fuel tank

A fuel tank it is necessary to fix so that the exit of fuel which can flow out from its bulk mouth, on the earth was provided.

The bulk mouth of a fuel tank should not be in salon, a luggage carrier, in a motor compartment. If the bulk mouth is located on a vehicle lateral face the filler cap in the closed position should not support car's body dimensions. Fuel which can spill at filling of a fuel tank, should not get on exhaust systems and electro wires. It should be taken away on a ground.

The fuel supply pump should be mounted as close to the fuel tank as possible and positioned below the tank's lower fuel level.

For the purpose of an exception of leak of fuel from a fuel tank by gravity at infringement of tightness of the fuel pump, a fuel tank it is preferable to have so that the fuel maximum level was below a cut of a fuel tube of a heater.

ATTENTION!

Before a heating season it is necessary to check a fuel tank. If the fuel was stored long time in a tank (for example from last heating season), it needs to be removed! To wash out a tank with gasoline or kerosene and to fill in new diesel fuel. This procedure is intended for removal of a deposit in fuel at long storage. Not performance of this procedure can lead to a contamination or failure of the fuel pump and the raised sooting in the combustion chamber.

Heaters of PLANAR-9D-12, PLANAR-9D-24 it is completed with the fuel pump for which mounted position has to be correspond to fig. 8.4a, i.e. $\pm 5^\circ$ from horizontal position.

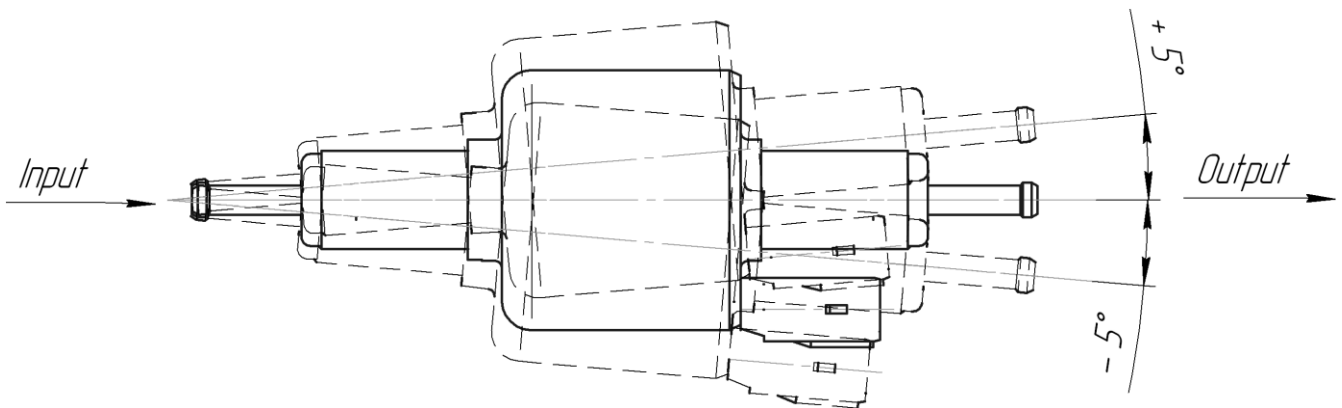

Figure 8.4a- Permissible mounting position of fuel pump

8.4.2. Installation a fuel supply intake in a regular tank of the car

Fuel supply intake must be installed into regular fuel tank of the car according to figure 8.5.

- Perform installation of special washer with fuel supply intake to the tank inlet according to figure 8.5
- Perform installation of the fuel supply line from fuel supply intake to the heater according to figure 8.6.

Attention!!! While manufacturing a hole in a regular fuel tank of the car it is necessary to fulfill safety requirements for works with tank which was filled with combustibile and explosive fuel.

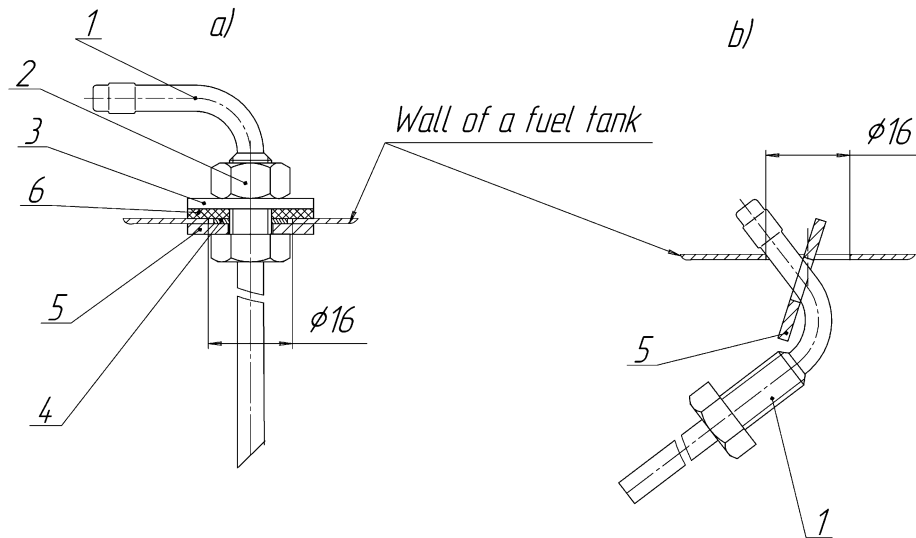

- | | |
|-----------------------|-------------------|
| 1- fuel supply intake | 4- washer 8 |
| 2- nut M8 | 5- special washer |
| 3- washer 8 | 6- gasket |

Figure 8.5 – Fuel supply intake installation in a regular tank of the car

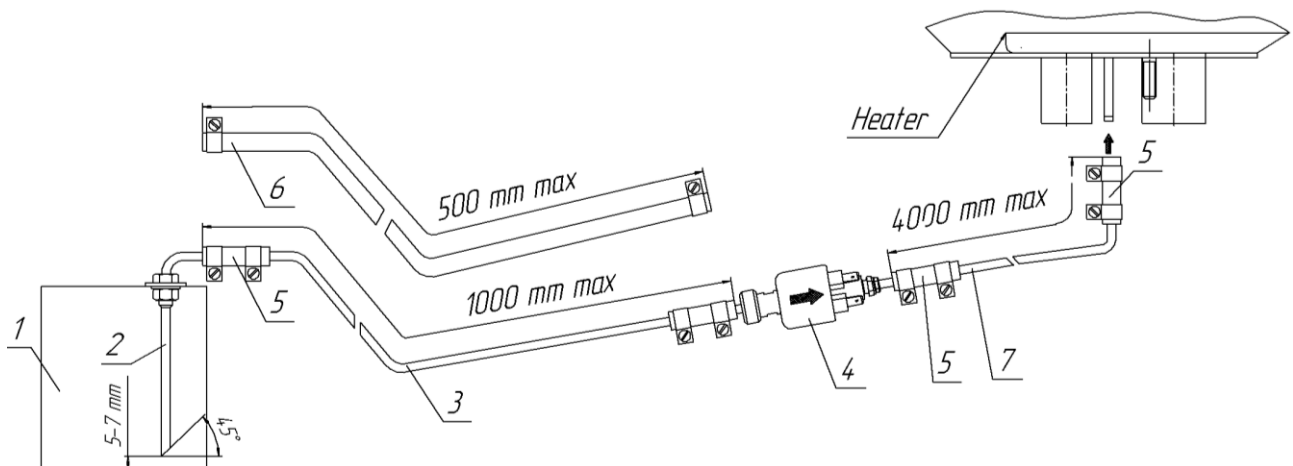

- | | |
|----------------------------------|-----------------------------|
| 1 – regular fuel tank of the car | 4 – fuel pump |
| 2 – fuel supply intake | 5 – sleeve |
| 3 – fuel supply line d=4 mm | 6 – fuel supply line d=5mm |
| | 7 – fuel supply line d= 2mm |

Figure 8.6 – Installation diagram for heater fuel supply system using a fuel supply intake

8.4.3. Fuel intake from return fuel pipe with T-connector

Allowed fuel intake from the return fuel pipe (unloading fuel from the engine to the tank) with T-connector. Return fuel pipe should be free of pressure and goes at the bottom of the fuel tank. The installation of the T-connector according to Fig. 8.7;

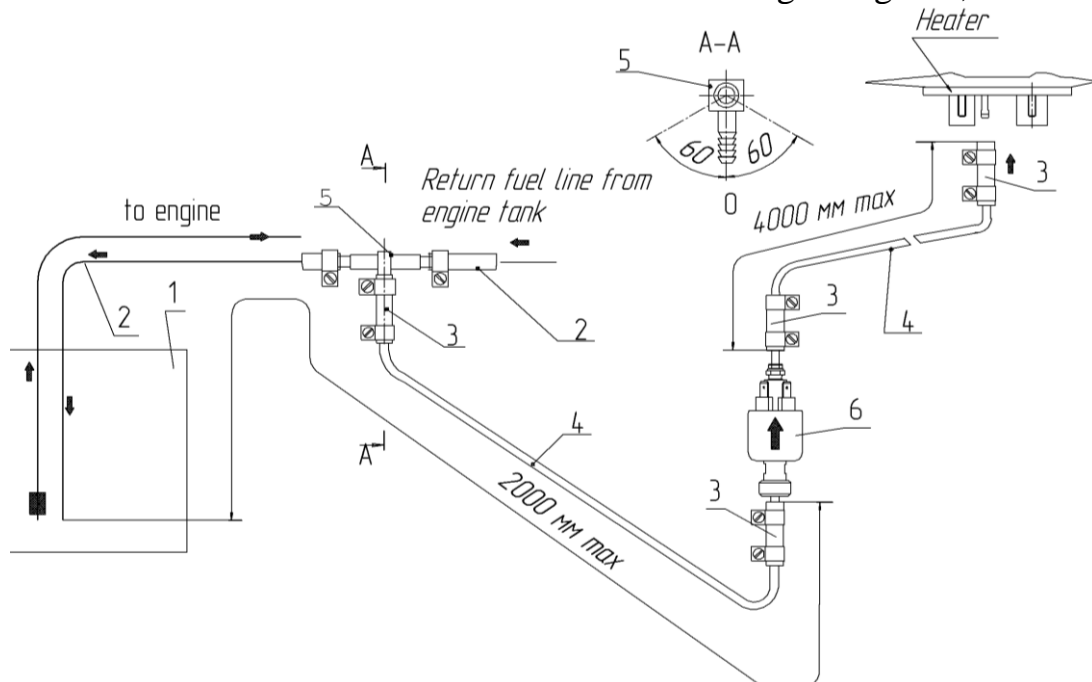

- | | |
|--|---|
| 1 - regular fuel tank | 4 - fuel supply line $d_y = 2\text{MM}$ |
| 2 - return fuel line from engine to tank | 5 - T-connector |
| 3 - sleeve | 6 - fuel pump |

Figure. 8.7 – Installation diagram for heater fuel supply system using return fuel pipe.

When installing the fuel supply line, do not allow connecting sleeves to bend. Use a sharp knife to cut the fuel tube as in figure 8.8. The cutting location shall be free of indentations, hairs and must not restrict flow through the tube.

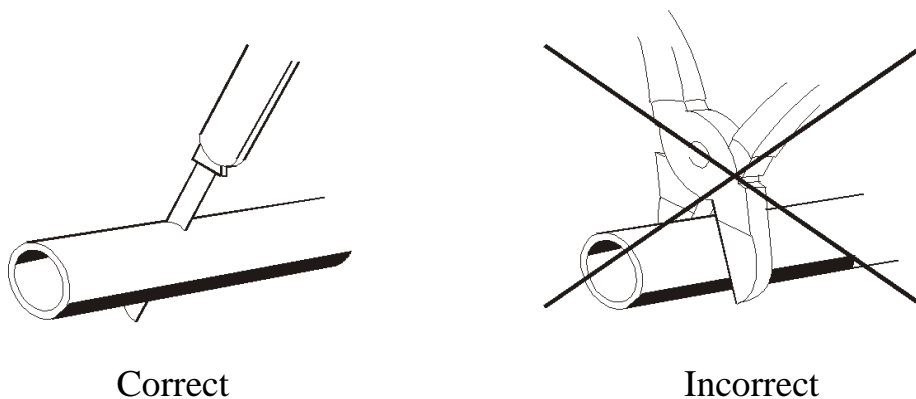

Figure 8.8 – Pipe cutting prior to installation

ATTENTION.

1. Do not allow the fuel supply line or fuel supply pump to overheat. Do not install the fuel supply line and fuel supply pump near the exhaust pipe or on the engine.
- 2 The fuel supply line connecting the fuel supply pump to the heating element of the heater should be installed at the same lifting angle.

8.5. Installation of heater electric circuit

Heater wire harnesses shall be installed in compliance with the heater wiring system as shown in figure 4.1. When installing, do not allow the wire harnesses to become overheated, deformed or dislodged during vehicle use. Attach the harnesses to the vehicle fittings using plastic clamps.

If it is necessary to truncate length of a harness of the fuel pump, it is allowed to cut out unnecessary part from the middle of a harness. The junction needs to be closed with a thermo shrinkable tube.

Attention! We recommend to cut a harness at distance of 500-700 mm from any of end of a corrugated tube of a harness and to cut out unnecessary part. To take wires, to remove isolation from the ends of all connected wires, to put a thermo shrinkable tube on wires and to twist wires of identical color. To establish a thermo shrinkable tube so that twist appeared in the middle of a tube. To heat a tube and to set it on wires. To put wires in a corrugated tube and to close a junction with an insulating tape.

Attention! Installation should be performed with the fuse disconnected.

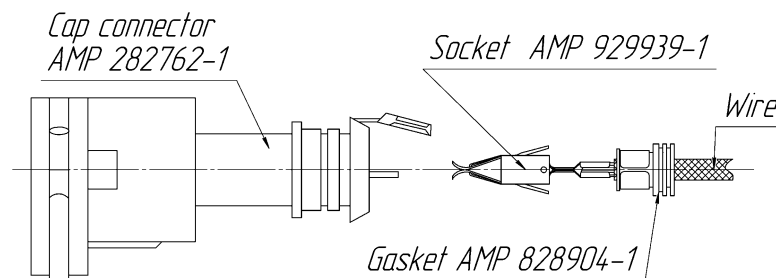

Figure 8.9 - Block and nest arrangement before installation

8.6. Control Panel installation and connection

Control Panel is installed in cabin or passengers compartment on the dashboard or any other comfortable for the driver place.

The connection of the Control panel to the heater is performed according wiring diagram (fig. 4.1)

9 Post-installation testing

9.1. When installing, ensure that:

- the fuel supply system is leak-proof
- the electric contacts of the harnesses and heater elements are securely installed

9.2. Install fuse 25A .

9.3. Fill the fuel pipe system with fuel with the help of fuel pumping device (fuel pumping device can be ordered at manufacturer).

9.4. Check that the heater is working :

- in ventilating mode,
- in heating mode.

The process of activation begins with purging of the combustion chamber. After purging the process of combustion begins and the heater goes on working in operation mode.

9.5. Deactivate the heater. While switching off the heater the fuel stops entering and the process of ventilation of the combustion chamber and heat exchanger starts.

9.6. Activate the heater while the vehicle engine is running and ensure that the heater is operational.

ATTENTION!

1. When performing initial ignition following installation, the fuel supply line should be filled with fuel using a fuel pumping device until the fuel level reaches the inlet plug of the heater. If there is no pumping device, restart the heater as many times as necessary to fill the fuel supply line.

2. Remember that each time the heater fails to start at the first attempt, the heater will be restarted automatically by the control unit.

10 Recommendations

- 10.1 To ensure consistent performance, the heater should be switched on for up to 5-10 minutes each month throughout the year (warm seasons included). This will prevent the moving parts of the fuel supply pump from sticking. Failure to comply with this advice may cause malfunctions in heater operation.
- 10.2 Reliable operation of heater depends on the type of fuel used. Type of fuel should be in accordance with GOST 305-82, depending on the ambient temperature (see Table 10.1). May be used and the mixture of fuel according to Figure 10.

Table 10.1

Ambient temperature, °C	Fuel type or blend
0°C and above 0°C	Diesel L-0, 2-40 Or L-02-62 GOST 305-82
0°C – -5°C (32°F – 23°F)	Diesel Z-0,2 mines 35 GOST 305-82
-5°C - - 20°C (23°F - -4°F)	Blend diesel Z-0,2 mines 45 GOST 305-82(50%) with petrol GOST P511050-97(50%)
Lower then -20°C (-4°F)	Diesel A-0.4 GOST 305-82 or blend diesel 3-0,2 mines 45 GOST 305-82 (50%) and petrol GOST P51105-97(50%)

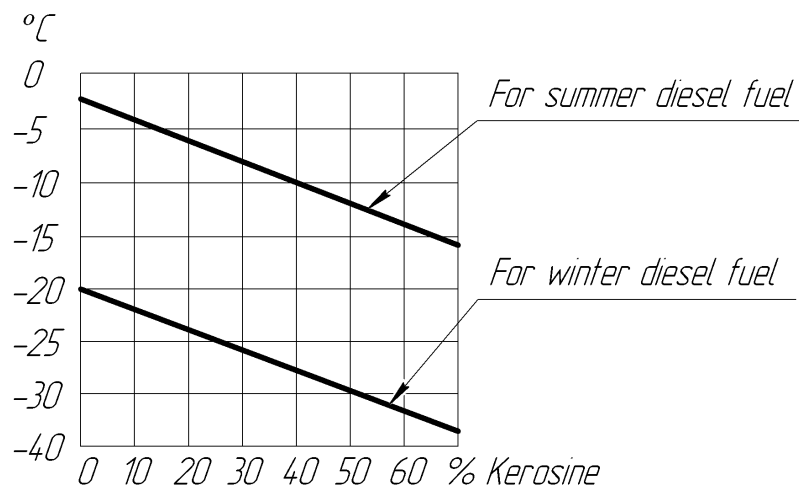

Figure 10 - Amount of kerosene mixed with diesel fuel, depending on the ambient temperature.

10.3 An untimely switch to a winter type of fuel may cause a paraffin blockage in the fuel inlet tube filter (if applicable) located in the fuel tank and in the fuel supply pump filter, which may prevent the heater from starting or cause it to stall in mid-operation.

To fix breakdowns, proceed to the following steps:

- 1) remove the fuel supply pump from the vehicle; using a wrench (F/A 17), fix the pump in place, unscrew the pipe stub and remove the filter (see figure 10). Do not fix the pump in place using surfaces other than surface A when removing and installing the pipe stub;
- 2) rinse the filter in gasoline and blast it with compressed air;
- 3) install the filter into the fuel supply pump; use sealant when installing the pipe stub;
- 4) install the fuel supply pump and check if the heater works.

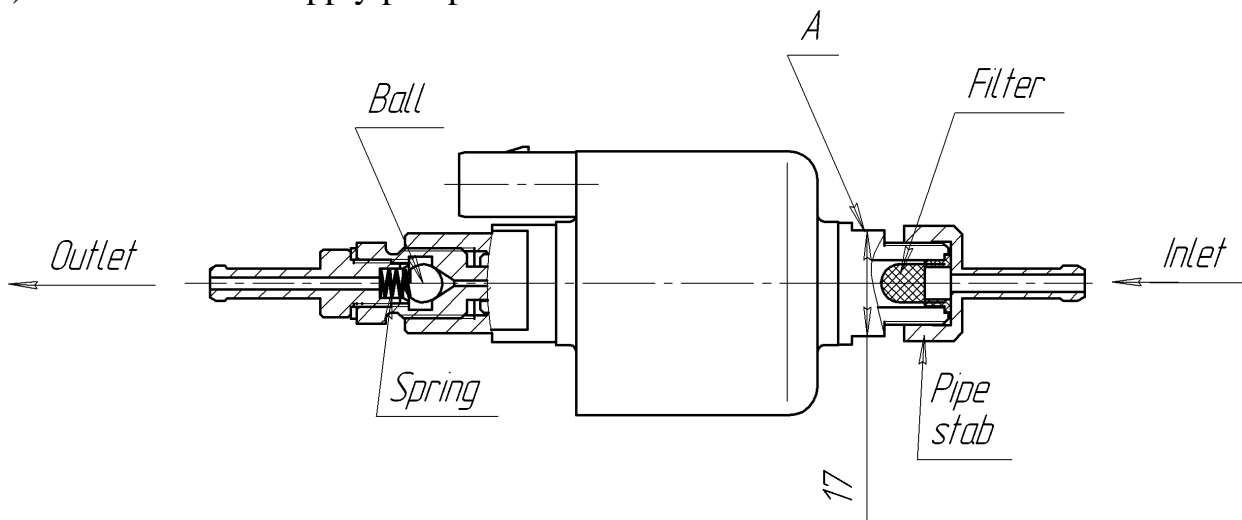

Figure 10. Fuel pump

10.4 Check **the battery charge level** on a regular basis.

10.5 It is recommended to switch on the heater with vehicle ground breaker closed.

10.6 While long storage of the vehicle it is recommended to switch off the heater from the vehicle battery to avoid its discharging (current consumption in non-operation mode 30-40 mA).

11 Possible malfunction during operations and Remedial Procedure for Heater Ignition Problems

11.1 Certain problems may be solved without contacting a maintenance station. If the heater does not operate when switched on, proceed to the following steps:

- 1) check the fuel level in the tank and in the fuel supply line beyond the fuel supply pump,
- 2) check fuse 25A,
- 3) check to see that all the contacts of the connectors and the fuse block are securely joined (contact corrosion is possible),

11.2 All other arisen malfunctions can be determined by quantity of blinkings of a light-emitting diode on the control panel (CP). The quantity of blinkings and codes of malfunctions are specified in manual of the control panel.

11.3 If there are malfunctions except those specified in 11.1, please contact an authorized maintenance station.

12 Transportation & storage

- 12.1 The heaters are safe to transport and may be transported by any means of transport, including air and rail transport providing the packed products are protected from atmospheric precipitations and climatic factors as per requirements specified in section 5 of GOST 15150-69 and mechanical effects as per requirements specified in category C of GOST 23216-78.
- 12.2 Storage conditions of heaters in packing of manufacturer have to correspond to storage conditions of 2 GOST 15150-69.
- 12.3 The period of storage heaters in packing of manufacturer order of 24 months.

13 Warranty

- 13.1 The warranty term of exploitation of heater outflows under reaching one of next terms:
 - the term of exploitation attained 24 months after the sale of good;
 - good worked a warranty resource - 2000 hours;
- 13.2 In default of stamp of organization with naming the date of sale a warranty term is calculated from the date of making of heater.
- 13.3 A manufacturer does not accept claim on incompleteness and mechanical damages after sale of heater.
- 13.4 A producer guarantees normal work of the heater on condition of observance by the consumer of all rules of exploitation, transportation and storage, indicated in this guidance. If a malfunction was found out during a warranty term, then she will be set free of charge. Installation of heater the organizations authorized by a producer must conduct. In this case, the warranty card is filled column «Information on installation.»

Warranty obligations do not spread to the defects arising up as a result:

- force-majeure circumstances: shots of lightning, fire, flood, impermissible violations of supply voltage,
- road a transport incident;
- failures to observe of rules of exploitation, storage and transporting;
- repair or adjusting, if they are conducted by the organizations, not authorized by a producer on installation of the heater and warranty repairing;
- refuse of work of heater by reason of contamination of combustion chamber;
- violations of work of electrical equipment of car;
- independent repair of heater or the use of unoriginal spare parts.

For the list of organizations performing warranty repair of Autoterm products see www.autoterm-europe.com.

Regarding any issues of technical service, please contact Autoterm LLC in Riga, Latvia by phone +371 25529999, or E-mail: service@autoterm-europe.com.